

# COLD ELECTRON BOLOMETERS FOR SUB-CM WAVELENGTH PHOTON COUNTING

Karthik Ramanathan

Washington University in St. Louis

Collaborators at:  
Arizona State University  
Cal State University East Bay  
Jet Propulsion Lab  
Lawrence Berkeley National Labs

BREAD Collaboration Meeting  
01/15/2026

 Washington  
University in St. Louis

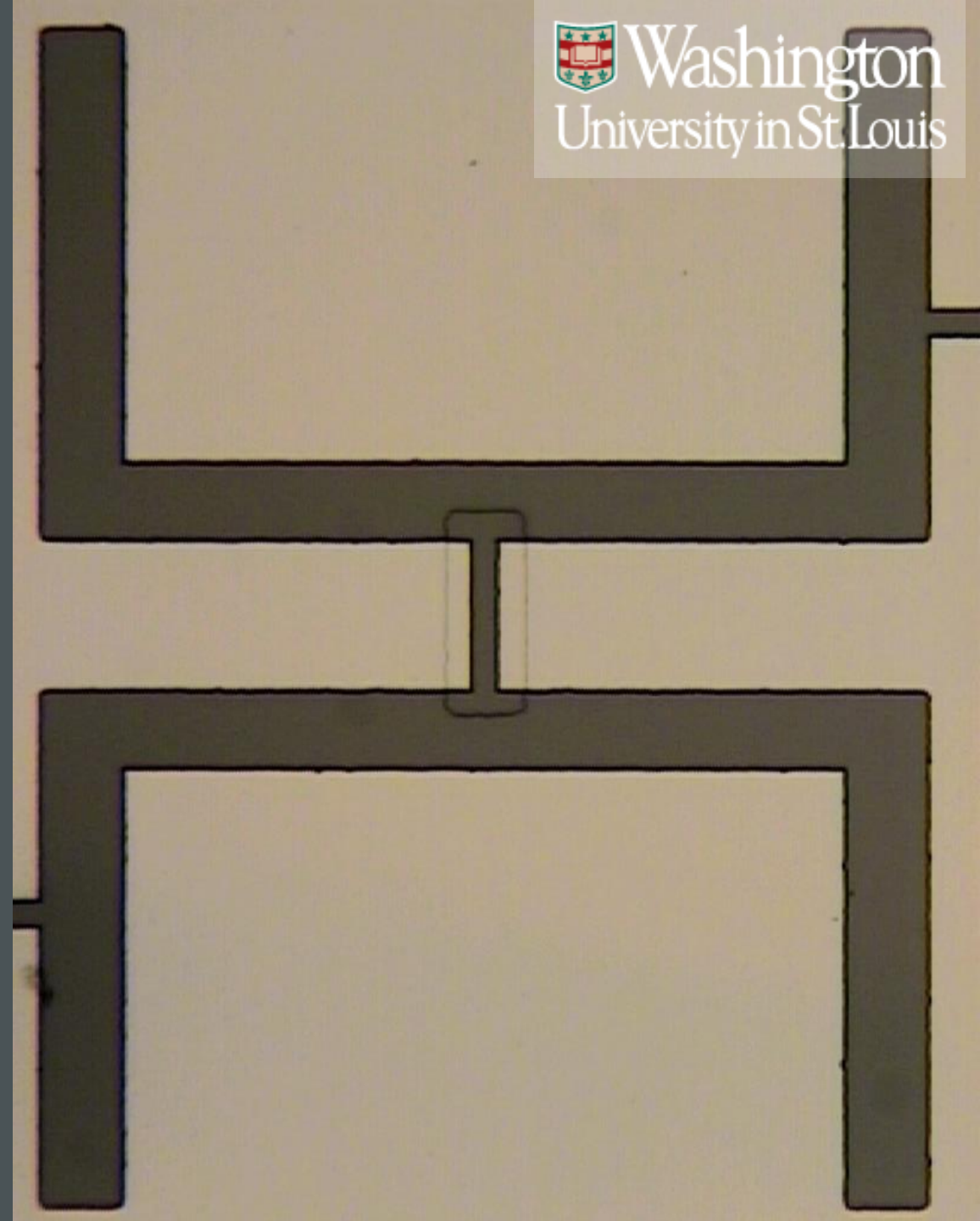

# Team



Phil Mauskopf  
ASU  
Previously part of team at Cardiff that built CEBs



Arran Phipps  
CSU East Bay  
Charge amplifier and readout



Adhitya Sriram  
ASU  
Grad student doing recent fab work



Nick Rodd  
LBNL  
Theory work



Karthik Ramanathan  
WashU St. Louis  
Design and Cryo-testing



Ritoban Basu Thakur  
JPL/Caltech  
Experimental design

# Axion Parameter Space

My understanding of long-term BREAD projections is that there are credible\* sensor techniques to span quite a large mass range.

\*My day job is working with KIDs\*\* and QCD-derived sensors so I'm aware of the complexities of running these sensors!

\*\*Member of QUALIPHIDE

What about the 20-100 GHz regime? Interesting because:

- “Post-inflationary” axion
- CaB

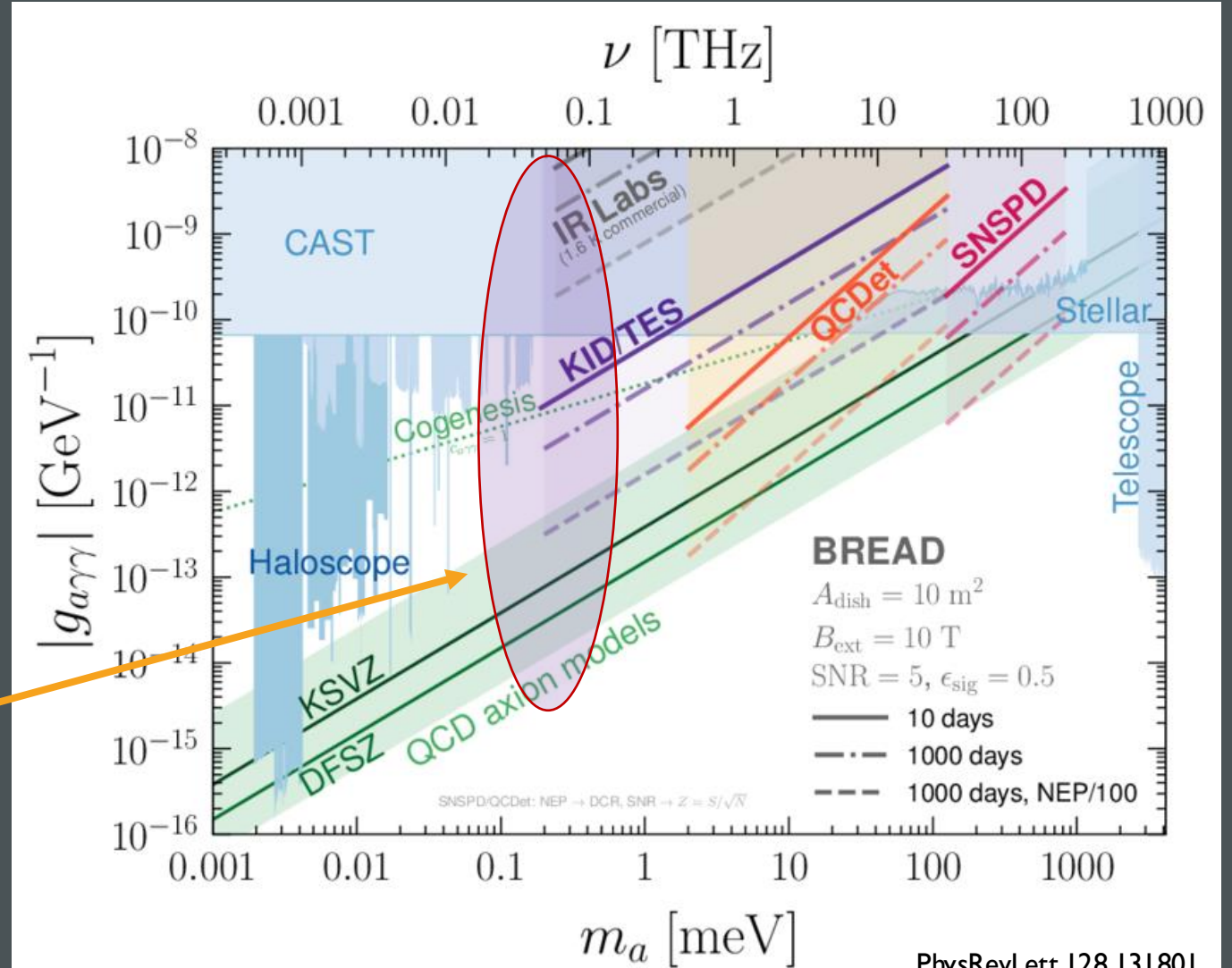

# Cosmic Axion Background

Recent theoretical work suggests that CaB might exist in a similar analogue to CMB and CvB

## Cosmic axion background

Jeff A. Dror<sup>1,2,3,\*</sup>, Hitoshi Murayama<sup>2,3,4,†</sup>, and Nicholas L. Rodd<sup>1,2,3,‡</sup>

PhysRevD.103.115004

Depending on production mechanism and cosmology – CaB landscape can span quite a wide frequency range.

Thermal production & having the CaB alleviate  $H_0$  tension would suggest **~30-60 GHz peak.**

| 20 GHz →

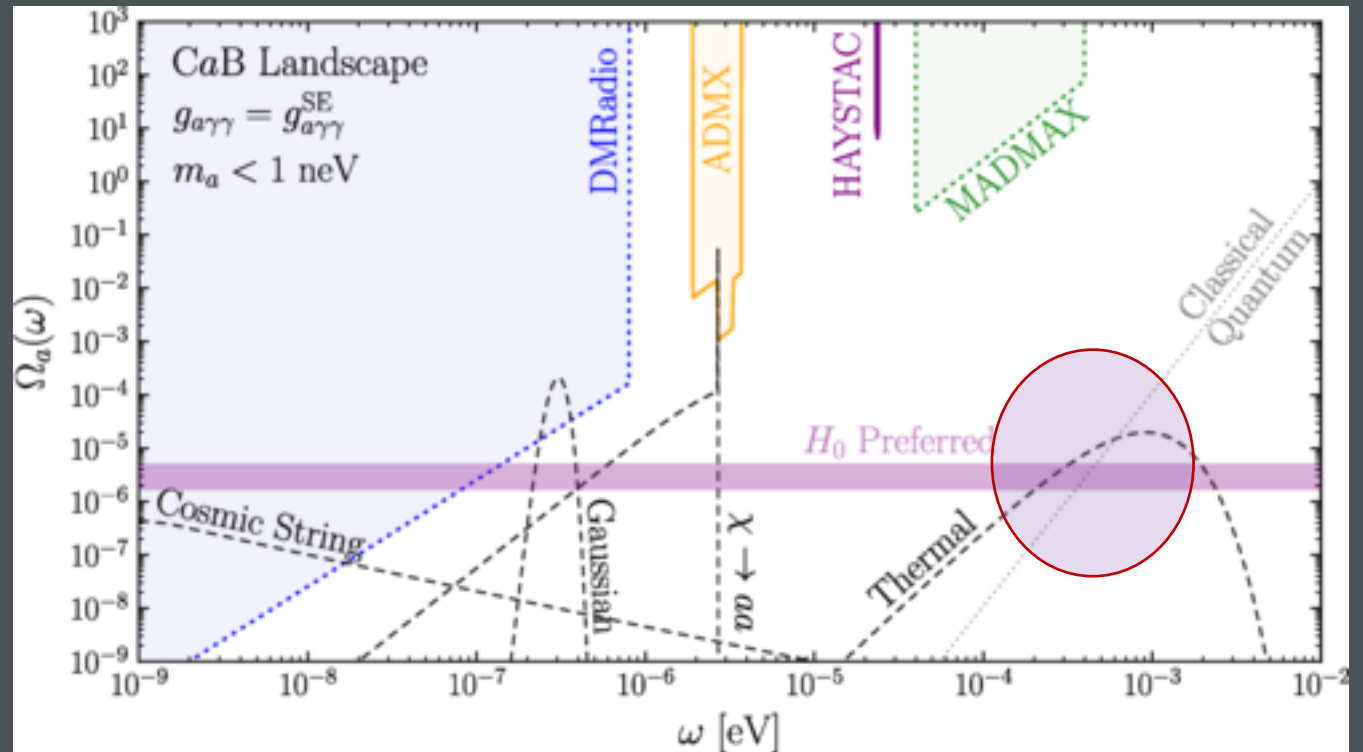

# Best search technique

*"Photon counting surpasses the standard quantum limit..."\**  
~ Sushkov, PRX Quantum 4, 020101 – 22 May, 2023

Generally speaking, **photon counting** is a better approach at these 10+ GHz frequencies as compared to radio receivers with linear amplifiers → Not limited by Standard Quantum Limit (SQL)

Note: a **broadband sensor** is warranted to best couple to a **broadband source**

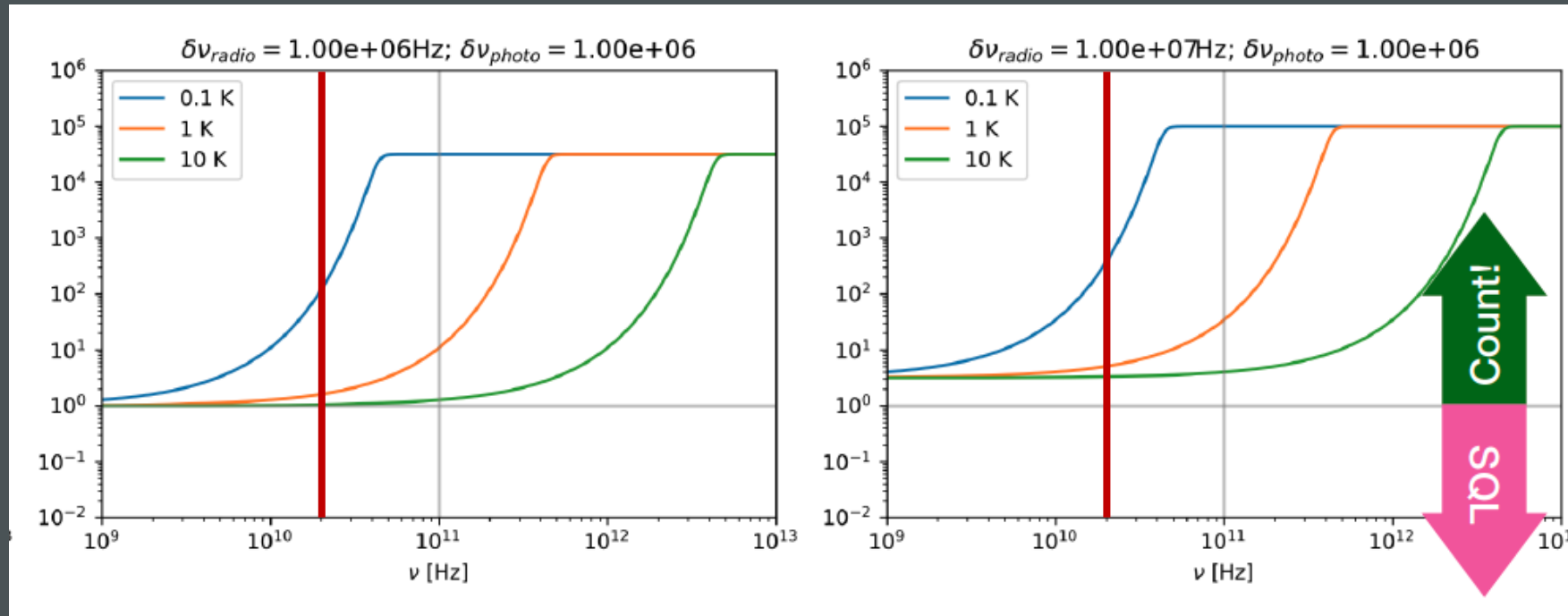

Plot from R. Basu Thakur UCLA DM 2025

# What's out there?

## Qubit SMPD

10.1103/PhysRevX.10.021038  
10.1103/PhysRevApplied.21.014043

- Qubit coupled to two resonators; uses state switching of qubit if photon enters one of the resonators

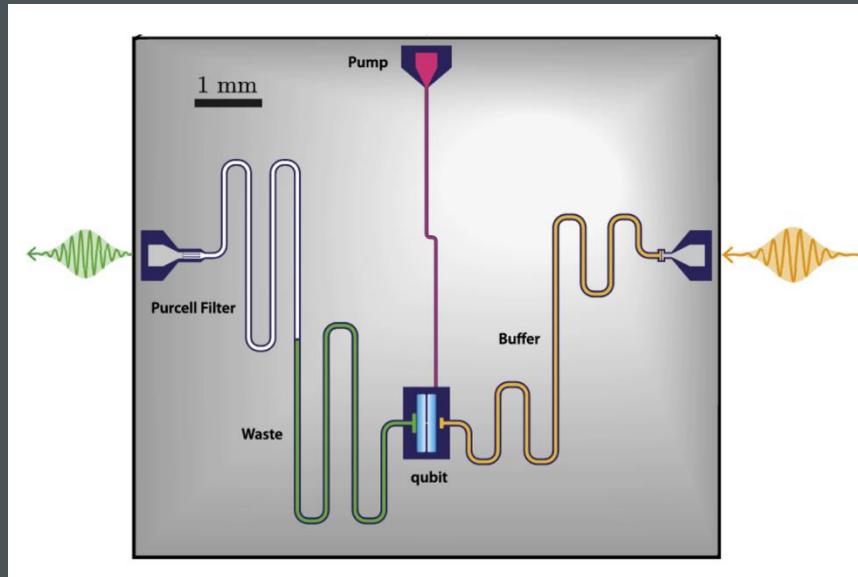

- + Demonstrated approach at 7 GHz with 80 Hz DCR
- + Can tune qubit to change band
- + Work being done to demonstrate this technique for 20+ GHz
- Narrowband; good for coupling to a cavity for example.

## Rydberg Atoms

10.1103/PhysRevD.109.032009

- Couple photon to stream of Rydberg atoms (atom with highly excited e-state) via absorption or stimulated emission.

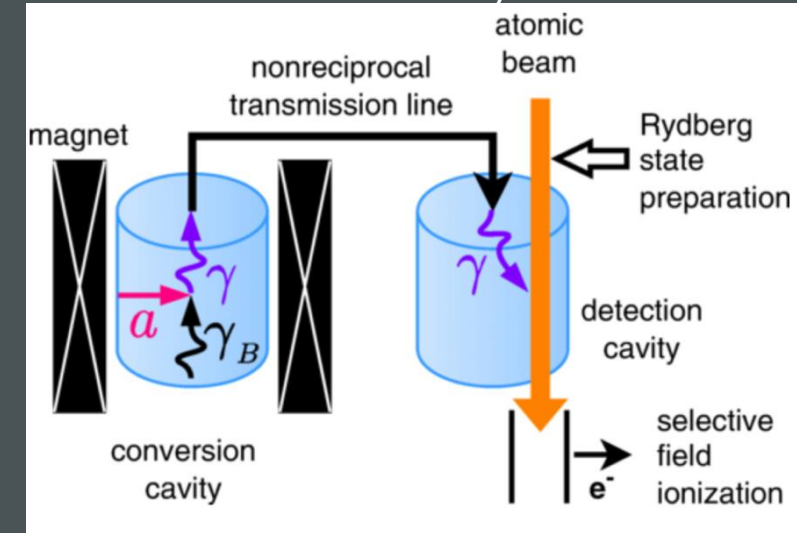

- + Possible operation 10-50 GHz
- +/- Tunable but only between specific transition frequencies
- Cavity based approach.
- Requires complex atom state preparation and other infrastructure

# What's out there?

## Graphene & Other Junction Based Bolometers

- SIS junction based device – graphene, Al examples
- Internal energy from a single photon triggers switching of junction to a resistive state

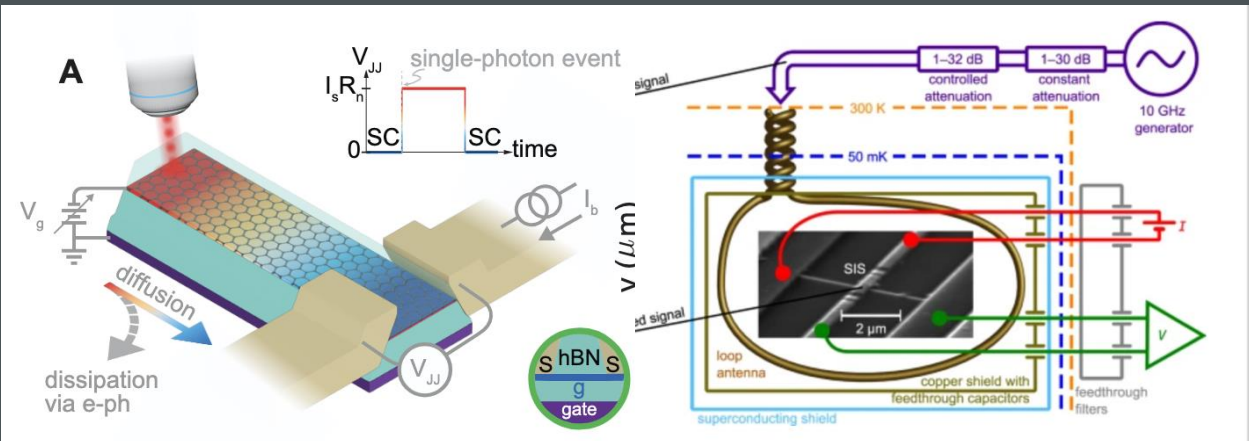

10.48550/arXiv.2410.22433. 10.1038/s41534-022-00569-5

- + Low demonstrated photon energy sensitivity (10 GHz)
- +/- Threshold based detection principle (tunable)

## Other things

- TESs – workable down to ~100 GHz
- Mixers – only for like 100 GHz+ and best at ~300 GHz
- SNSPDs – have only demonstrated sensitivity to 100+ meV (20+ THz) photons.
- KIDs/QCDs – would need to be made of much lower gap material than Al (e.g. Hf, Ir). Will have to address DCR for QCDs.
- Tell me about your favorite technology!

# Cold Electron Bolometers

First proposed by Kuzmin et al early ~2000s for CMB applications

At its heart Superconductor-Normal Metal-Superconductor (SNS or SINIS) junction.

1. Biased near  $eV \leq \Delta$ . Shape of potential means that high energy electrons preferentially tunnel into the superconductor, **removing energy from absorber**.
2. **Very weak** electron phonon coupling, and hot electron escape (i.e. cold electrons are left), allows  $T_e$  to be driven **below** lattice temp.

$$P_{e-ph} = \Sigma V (T_e^5 - T_{ph}^5)$$

3. Photon absorption occurs in normal metal, perturbs the cold steady state.

$$P_{e-ph} + P_{bias} - P_{cool} = 0$$

4. Signal readout is done via measuring **tunneling current** (voltage bias) or **voltage** (current bias)

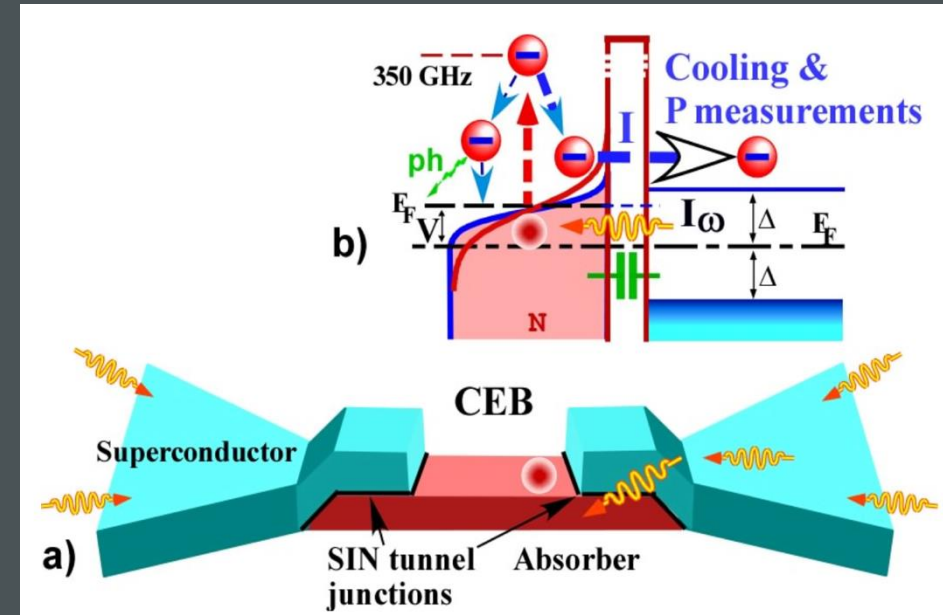

10.1016/S0921-4526(99)03032-X

Strong cooling  $\rightarrow$  **very fast relaxation times, on the order of  $O(100)$  ns**



# Previous results I

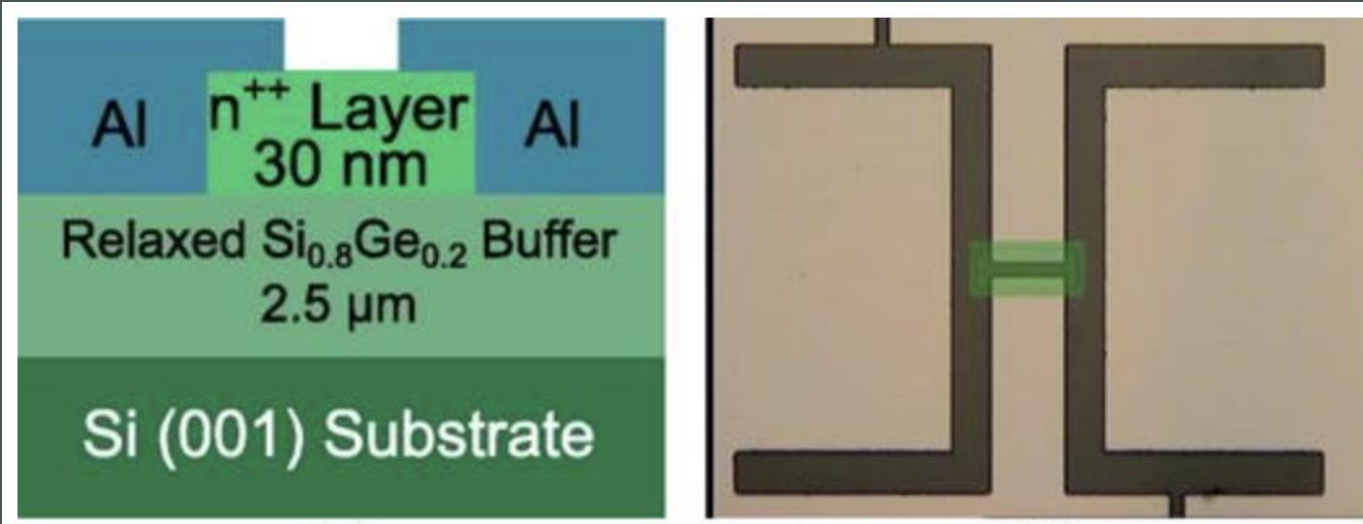
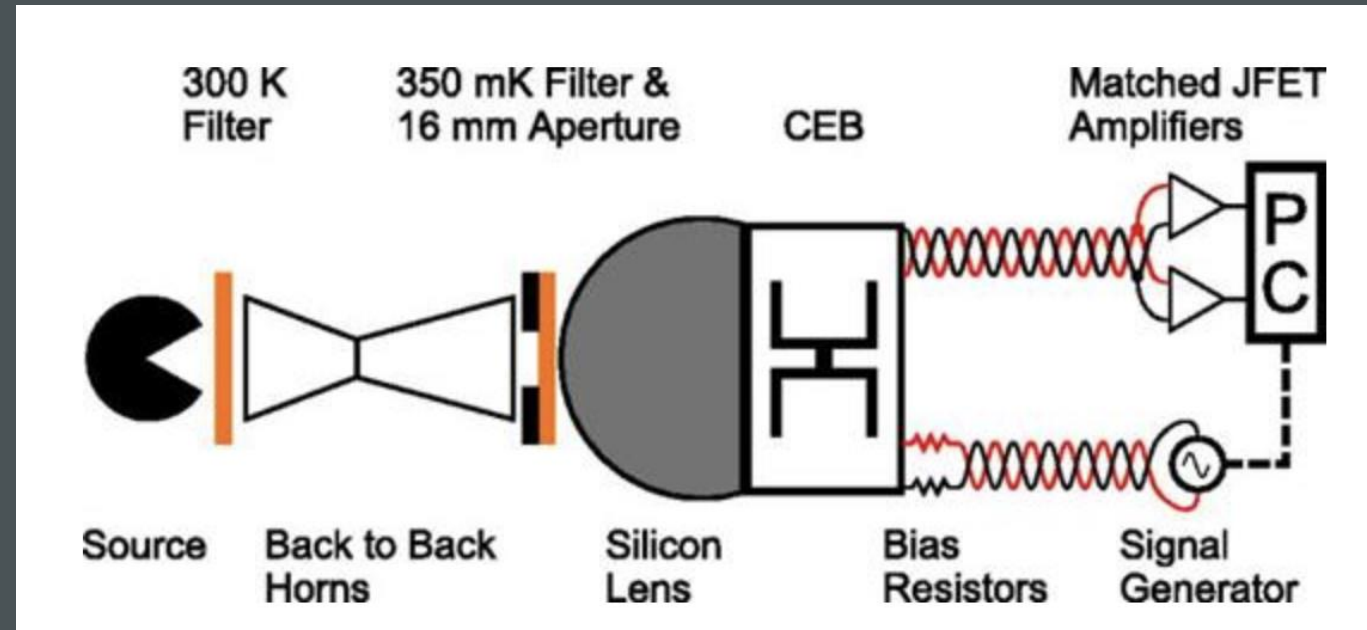

Table 4.3: Summary of key material properties for unstrained (control) and strained silicon materials.

Parameter	Unstrained	Strained
Dopant Concentration ( $\text{cm}^{-3}$ ) <sup>a</sup>	$4 \times 10^{19}$	$4 \times 10^{19}$
Strain Layer <sup>a</sup>	N/A	$\text{Si}_{0.8}\text{Ge}_{0.2}$
Carrier Density ( $\text{cm}^{-3}$ ) <sup>a</sup>	$3.1 \times 10^{19}$	$2.7 \times 10^{19}$
Mobility ( $\text{cm}^2 \text{V}^{-1} \text{s}^{-1}$ ) <sup>a</sup>	192	155
Electron-Phonon Coupling, $\Sigma$ ( $\text{WK}^{-6} \text{m}^{-3}$ ) <sup>b</sup>	$5.2 \times 10^8$	$2.0 \times 10^7$
Sheet Resistance ( $\Omega/\square$ )	384	571
Al-Si Junction Resistance ( $\text{k}\Omega \mu\text{m}^2$ )	13	512

- Brien et al. fabricated a series of siCEBs and calibrated them with blackbody sources.
- Used **strained** silicon, epitaxially grown via a SiGe buffer layer – straining increases e-mobility and reduces electron-phonon coupling



# Previous results II

IV curve, along with inset electron temperature

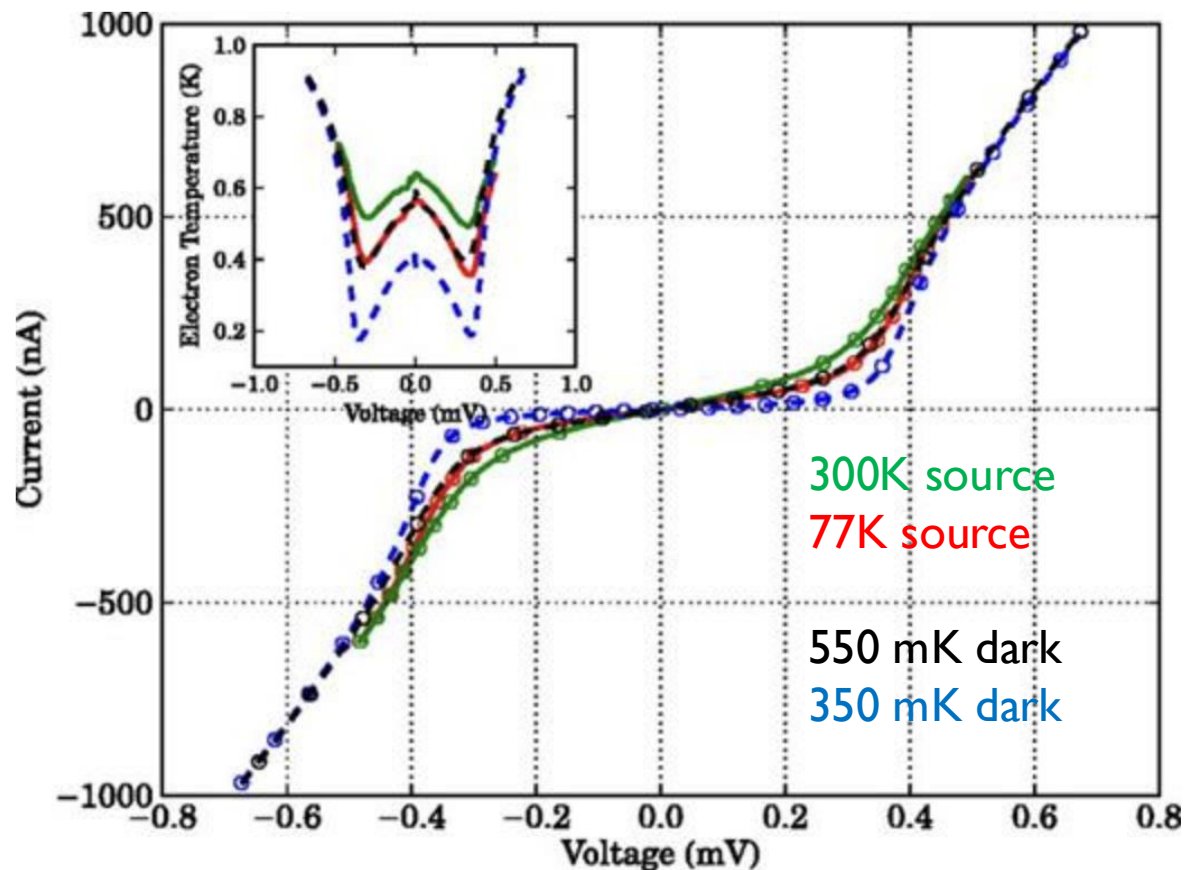

Responsivity to an FTS with mercury arc lamp source

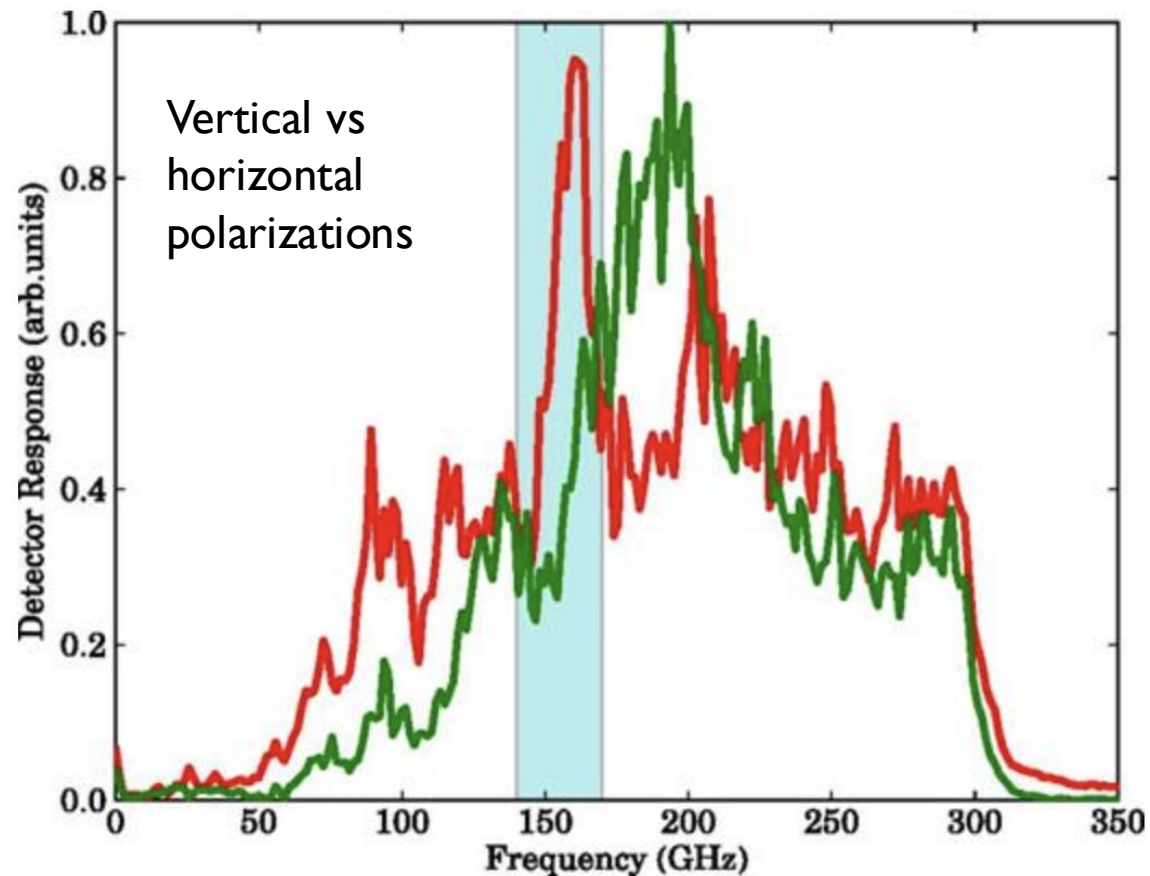

# Program goes nowhere for CMB

10.1063/1.4892069

optical loading conditions has an electrical or dark noise equivalent power, at 350 mK, of

$8.3 \times 10^{-18} \text{ W Hz}^{-1/2}$ . The time constant of this detector has been determined to be less than  $1 \mu\text{s}$

+ Demonstrated responsivity to  $O(100)$  GHz optical illumination, NEPs competitive with CMB experimental requirements.

but:

- By early 2000s TESs had already demonstrated: background limited performance, excellent uniformity, multiplexability (SQUIDs) into large arrays

and:

- Non-semiconductor devices require precise junctions and fab
- Have narrow optimal operating bias points
- Saturates at comparably lower power – low dynamic range
- Lots of wiring (biases), and individual current/voltage readout channels.

# Alternative application

Parameter	Brien 2014 Design	Enhanced CEB
Phonon bath temperature ( $T_{\text{ph}}$ )	300 mK	20 mK
Silicon mesa dimensions	$34\mu\text{m} \times 15\mu\text{m} \times 30\text{ nm}$	$5\mu\text{m} \times 5\mu\text{m} \times 30\text{ nm}$
Junction normal resistance ( $R_N$ )	$290\ \Omega$	$7250\ \Omega$
Electronic heat capacity ( $C_V$ )	$6 \times 10^{-18}\text{ J/K}$	$2 \times 10^{-20}(T_e/20\text{mK})\text{ J/K}$
Electron temperature ( $T_e$ )	150 mK	$< 10\text{ mK}$
Thermal relaxation time ( $\tau_r$ )	200 ns	$< 1\text{ ms}$

Decrease mesa volume & decrease bath temperature  $\rightarrow$  Drops electronic heat capacity by 2 orders of magnitude  $\rightarrow$  Increased responsivity to smaller heating events  $\rightarrow$  useful for low energy photons!

Use of bias dramatically improves charge production vs. pair-breaking sensor

$$R_{\text{CEB}}(e/\gamma) \propto \frac{h\nu}{2\Delta - eV} \quad \text{c.f.} \quad R_{\text{pair-breaking}}(e/\gamma) \propto \frac{h\nu}{\Delta}$$

# Some preliminary modeling I

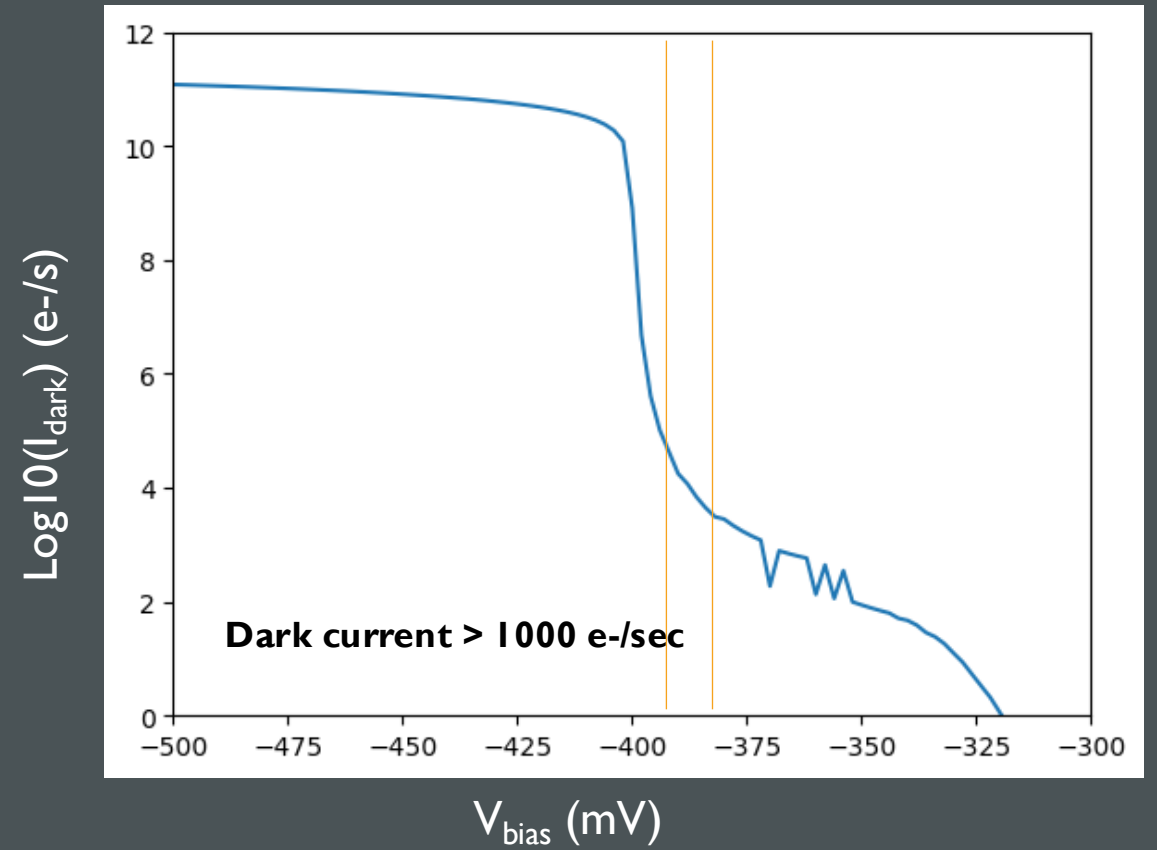
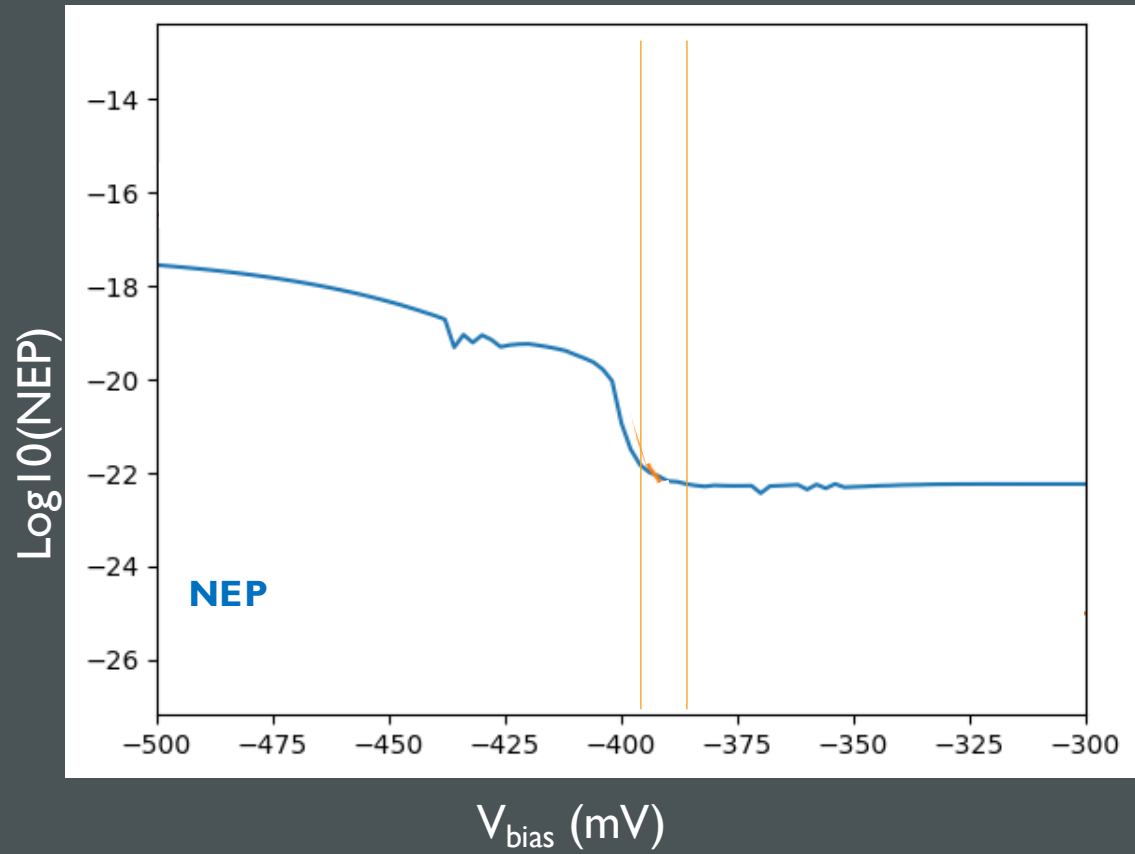

# Some preliminary modeling II

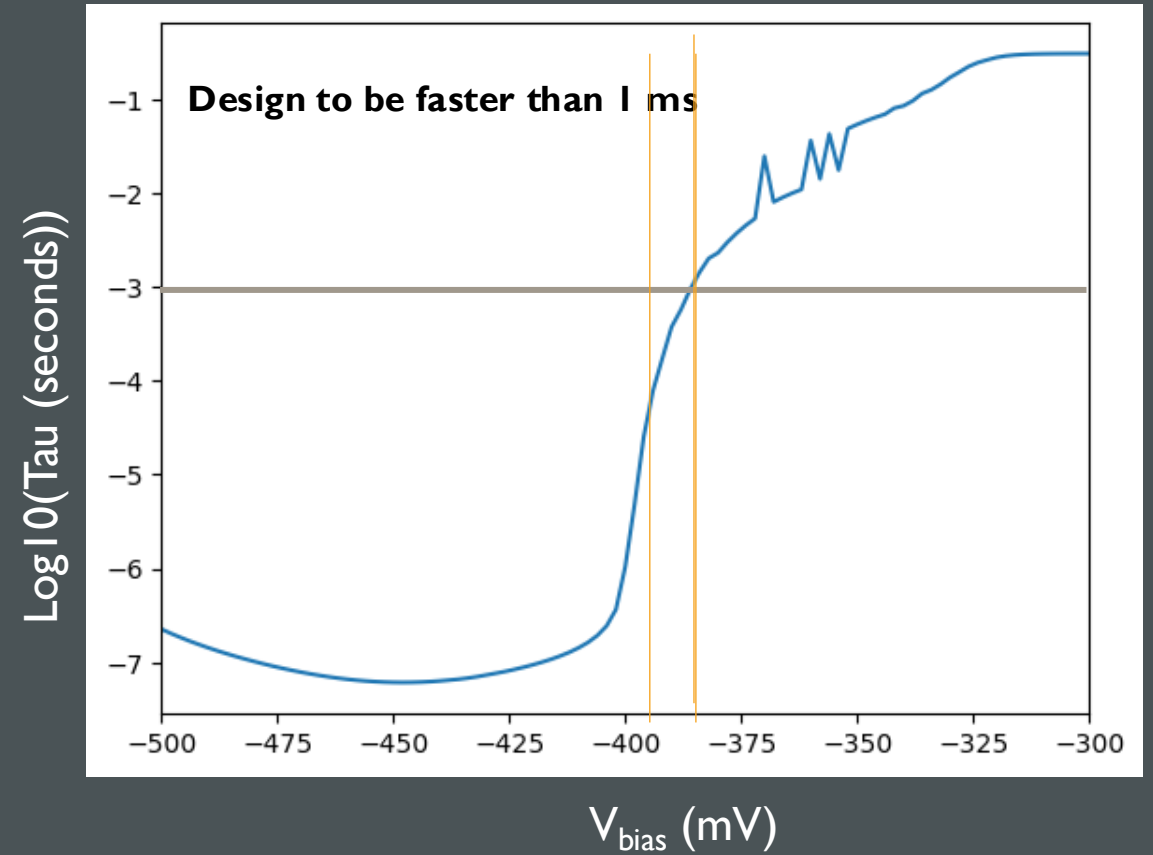
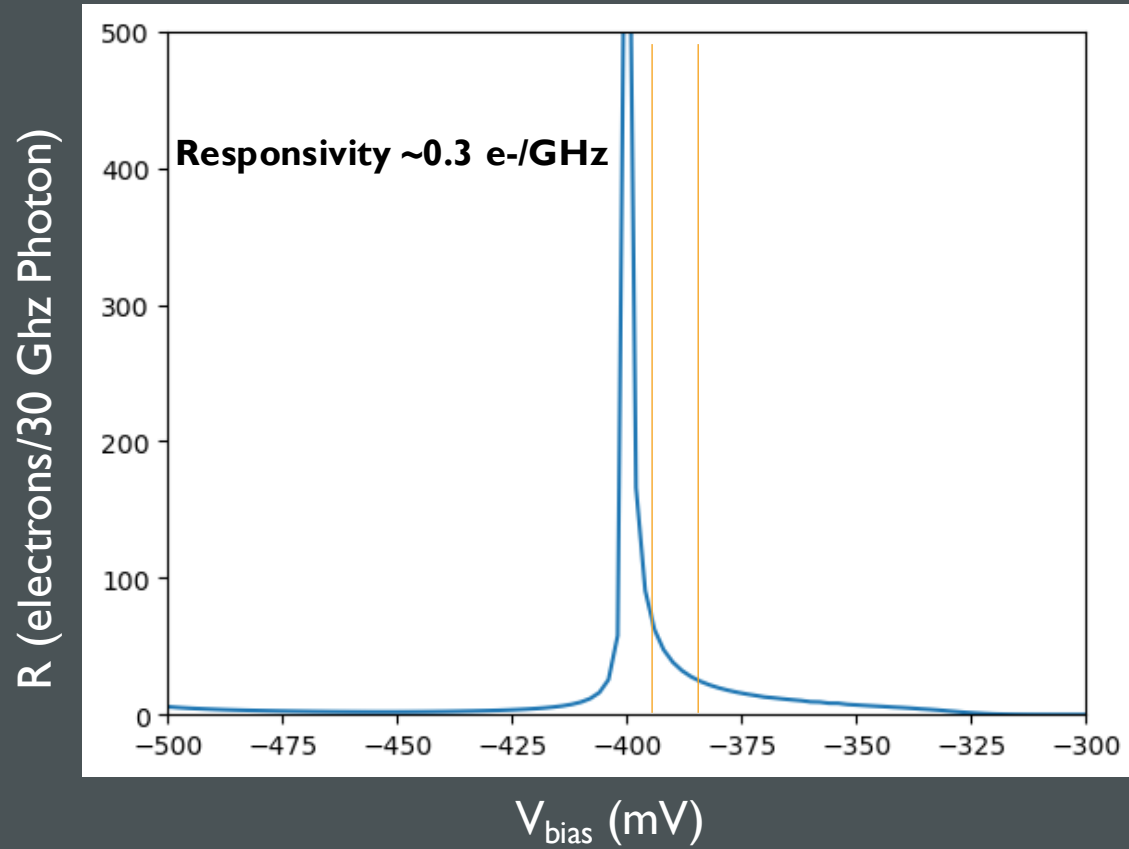

# Some preliminary modeling III

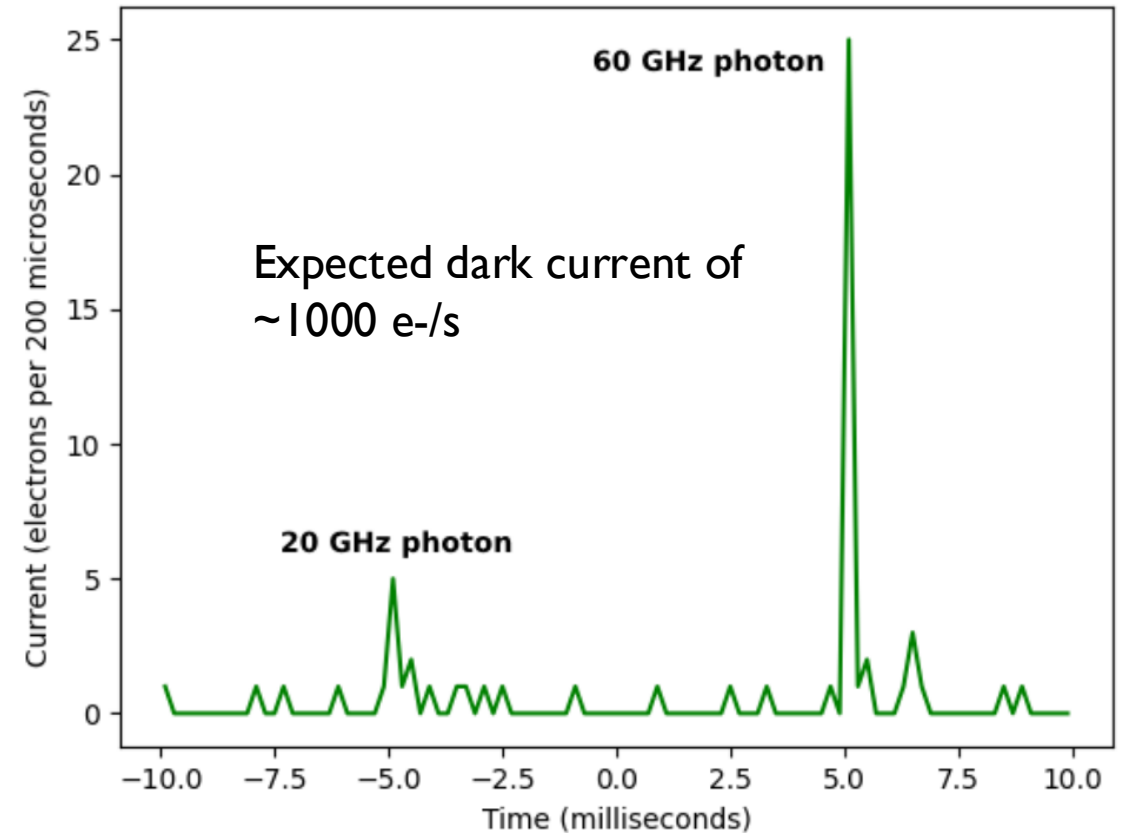
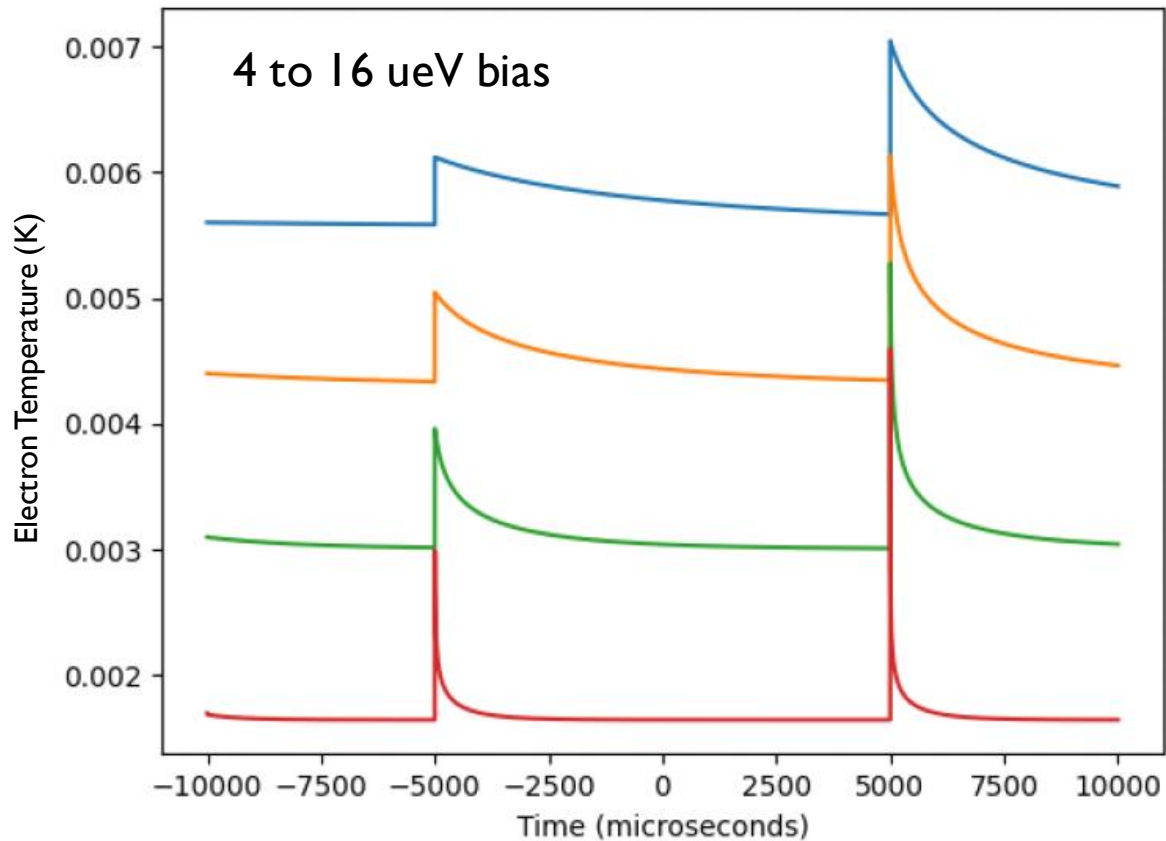

Preliminary simulations & calculations suggest **observable pulses** with  **$O(100)$  us** lifetimes from  **$O(10)$  GHz photon absorption**.

# Current Work

This is not a funded project. We've cobbled together a few \$k

- ASU designing CEB masks
  - Initial fab work on Nb and Al structures on Si wafers underway
  - Waiting on doped & strained-Si wafers for actual CEB production
- WashU setting up measurement apparatus for characterizing devices; we will pulse these on feedline by way of a 40 GHz signal generator
- CSU East Bay working on low noise readout chain, recycling existing hardware

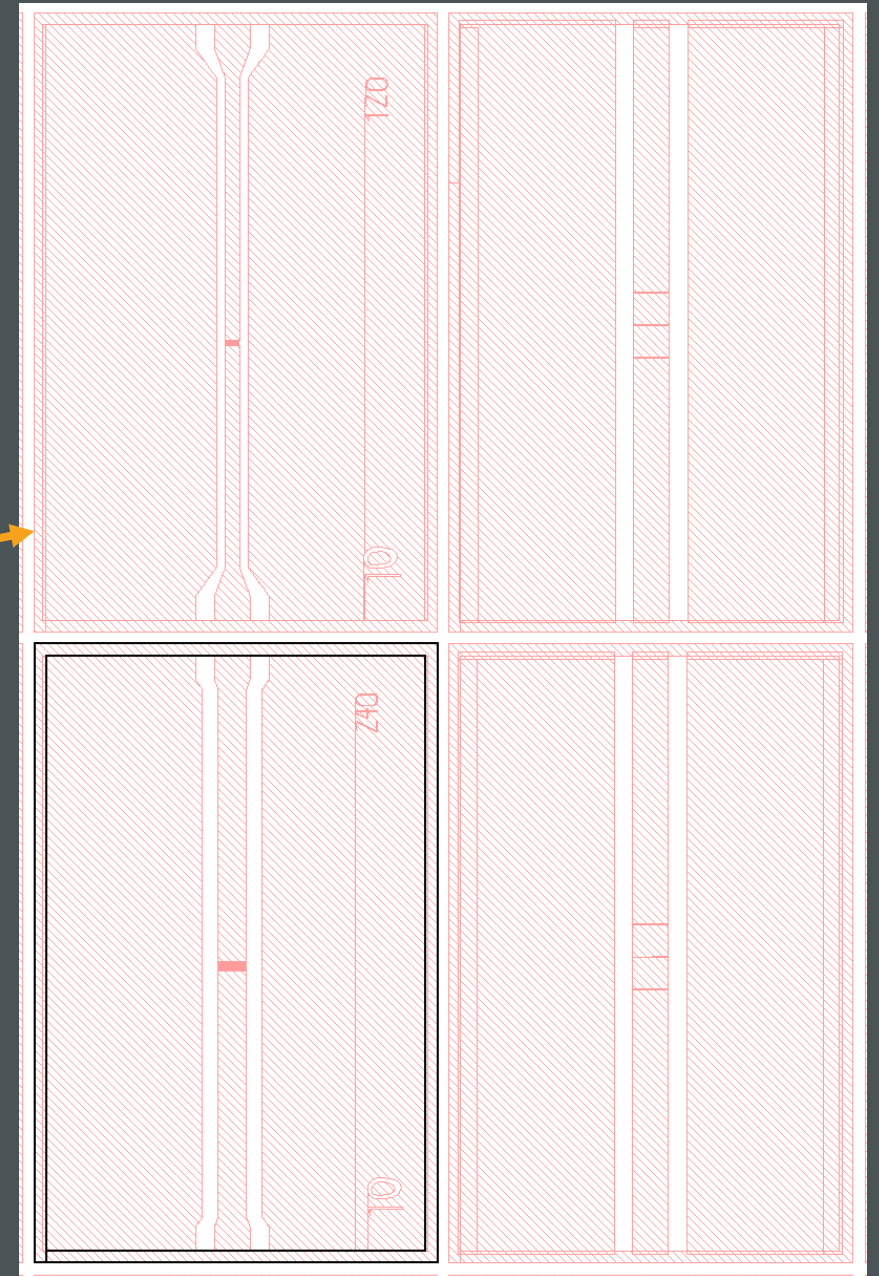

# Enhanced readout strategies

10.1007/s10909-023-03046-1

- Two stage FET amplifiers being developed for the SPLENDOR experiment (10.1007/s10909-023-03046-1) with **demonstrated 7-20 e- resolution.**
- Tosi et al. have sketched a Cooper-Pair Box Electrometer with potential for **single e- resolution**
- But for now, we will start with **off the shelf JFET** solution

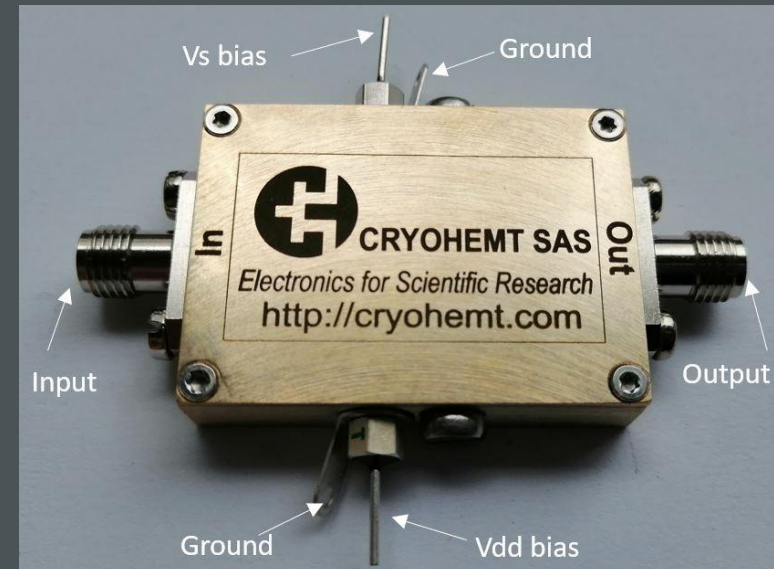
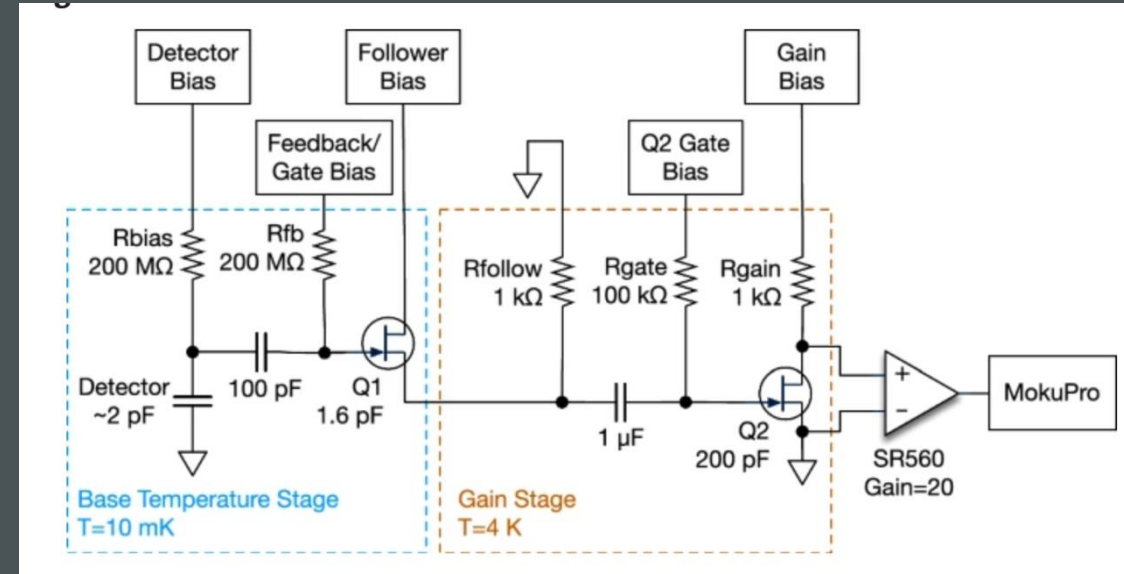

# Lots of challenges to explore & overcome

## Detector

- **Superconducting sub-gap states** limiting dark resistance
- **Back tunneling** of quasiparticles limiting thermal conductance
- **Stray power absorption** limiting  $T_{\text{electron}}$
- ...

## ALP Search

You will note I have said almost nothing about how one would integrate this with an actual ALP experiment.

- **Coupling** of radiation (**antenna?**)  $\rightarrow$  all those **efficiencies??**
- **Multiplexing scheme** if needed
- ...

THANKS! QUESTIONS?

([karthikr@wustl.edu](mailto:karthikr@wustl.edu))

